

CDL
世纪德利

点支式幕墙配件·扶手系列
Point curtain wall fittings·Handrail series

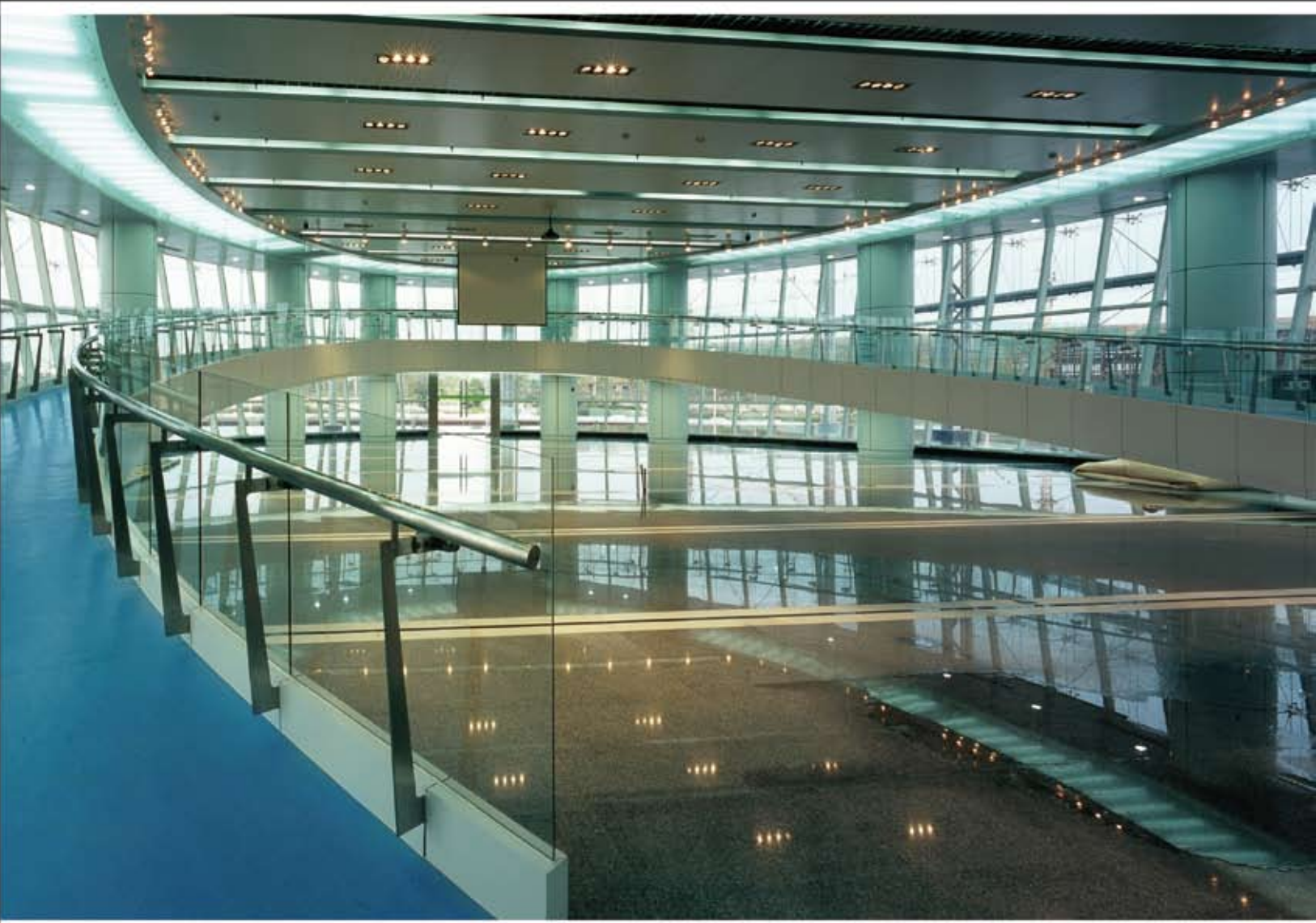

泰州世纪德利金属制品有限公司
TAIZHOU CENTURY DELI METAL PRODUCTS CO.,LTD.

BRIEF INTRODUCTION 企业简介

泰州世纪德利金属制品有限公司位于中国不锈钢名镇——江苏姜堰兴泰镇。是一家专业生产不锈钢产品的大型企业，品种齐全，规格全面。

本企业主要产品有不锈钢扶手栏杆、点支式幕墙配件、扶手配件、泳池玻璃夹、不锈钢井盖、非标等产品。广泛应用于桥梁、机械五金。高效、灵活的管理机制，大量优秀的专业人才，高起点的研发战略，先进的生产设备，完善的质量保证，遍布各地的营销网络，构建了本企业持续、快速发展的支撑系统。

进入新世纪，本企业将以实惠的价格，以市场为导向，增强企业的实力，多元化、连锁化、信息化、追求更高的企业价值；以顾客为导向，持续增强企业控制能力，重目标、重执行、重结果，追求更高的顾客满意。持之以恒，矢志不渝地打造中国最优秀的不锈钢产品。



楼梯立柱

CDL
世纪德利

楼梯立柱
扶手

幕墙配件
驳接爪件

客户服务 Customer service

我们推崇客户至上的理念：

- 按时交货；
- 保持大量材料库存，满足客户需求；
- 现代化集成软件系统，提高工作效率；
- 快速报价，通常在电话上就能完成。



幕墙配件

STAINLESS STEEL SERIES

不锈钢系列

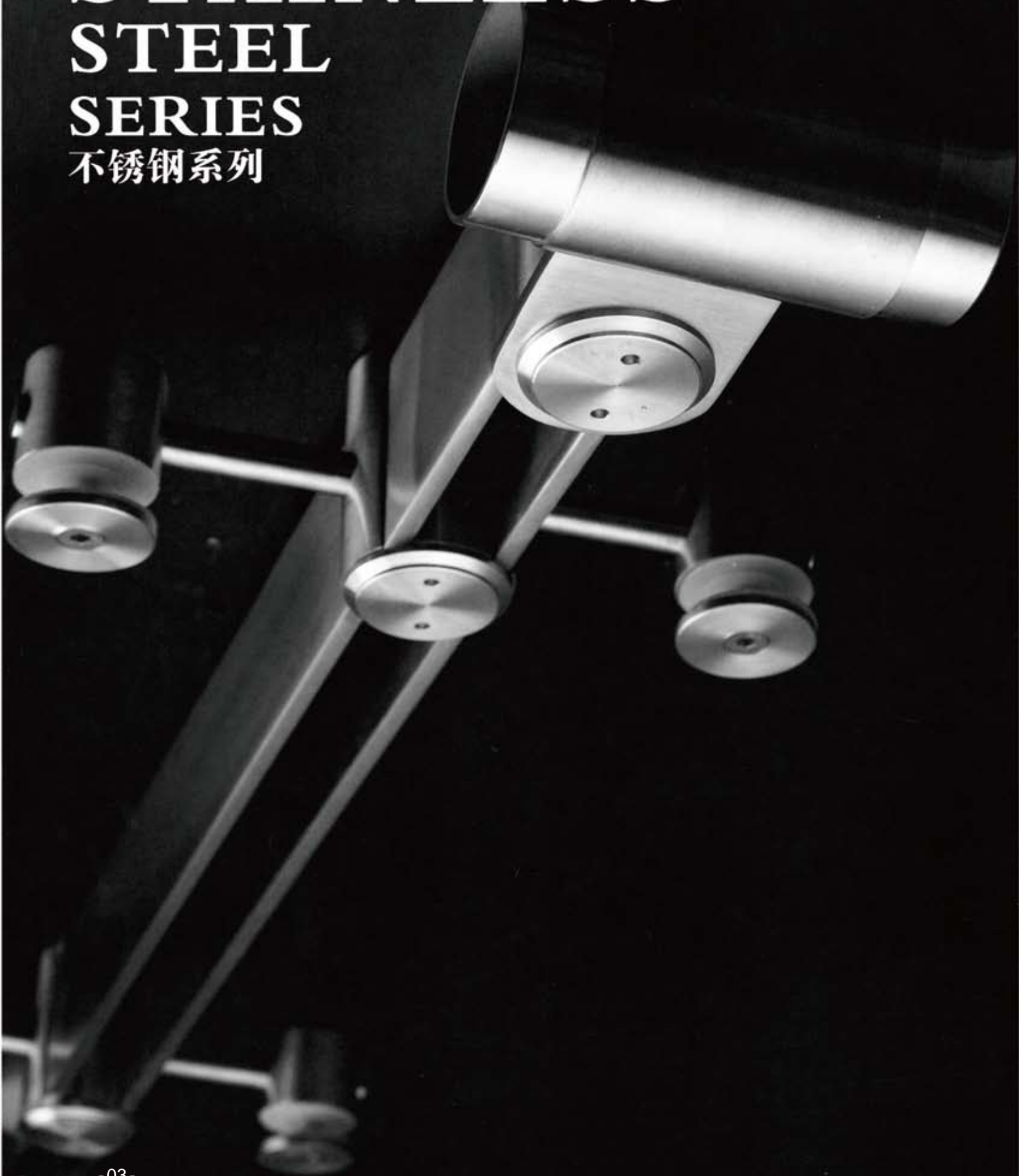



公司生产设备 Company production equipment

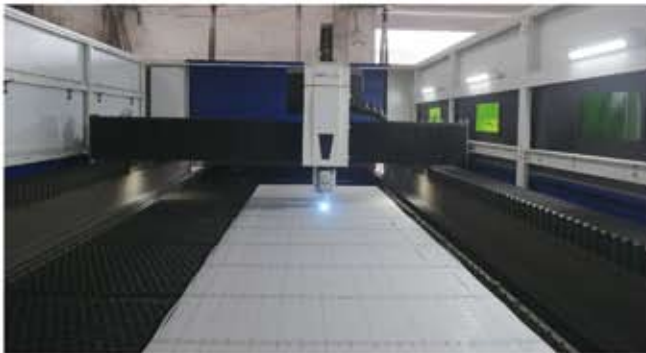

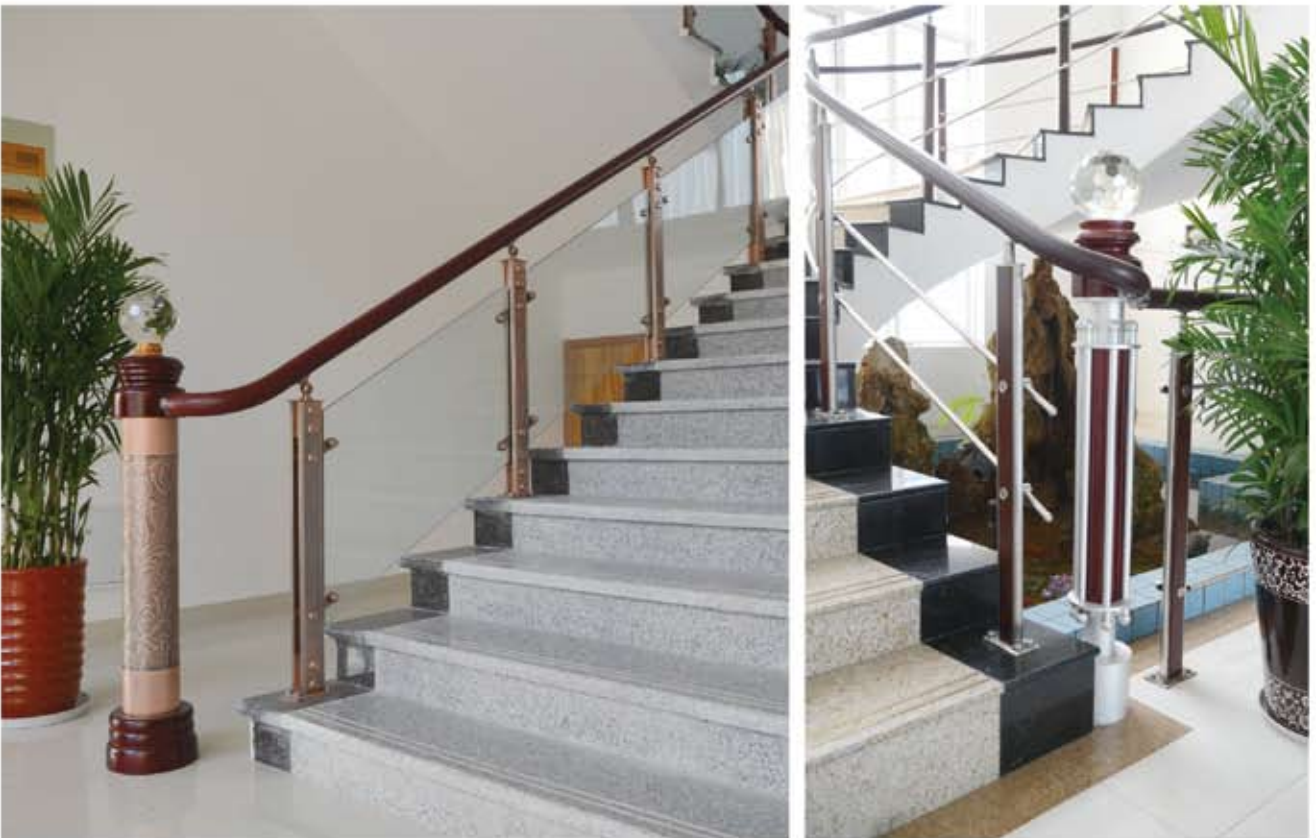

















泰州世纪德利金属制品有限公司
TAIZHOU CENTURY DELI METAL PRODUCTS CO.,LTD.







泰州世纪德利金属制品有限公司
TAIZHOU CENTURY DELI METAL PRODUCTS CO.,LTD.







MODEL: 1001

表面处理: 砂光
Finish: Polishing

材质: 不锈钢
Material: stainless steel





弹性化空间运用，可因不同需求而产生变化，从而达到最高使用效益；每种材质与现代精湛工艺完美结合，质感丰富而具品质保证，创造更高的使用价值。

MODEL: 1002

表面处理：砂光

Finish: Polishing

材质：不锈钢

Material: stainless steel

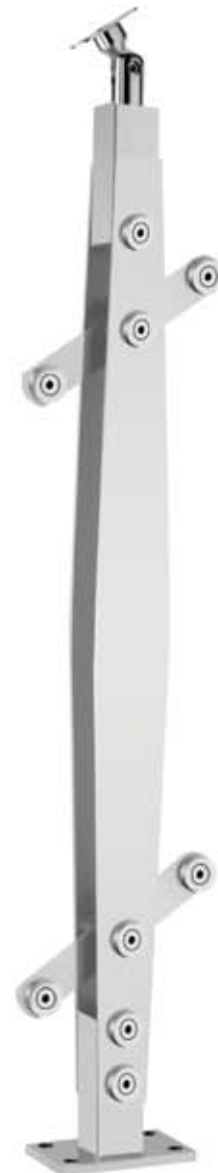



MODEL: 1003

表面处理: 砂光
Finish: Polishing

材质: 不锈钢
Material: stainless steel



MODEL: 1004

表面处理: 砂光
Finish: Polishing

材质: 不锈钢
Material: stainless steel





MODEL: 1005

表面处理: 砂光
Finish: Polishing

材质: 不锈钢
Material: stainless steel

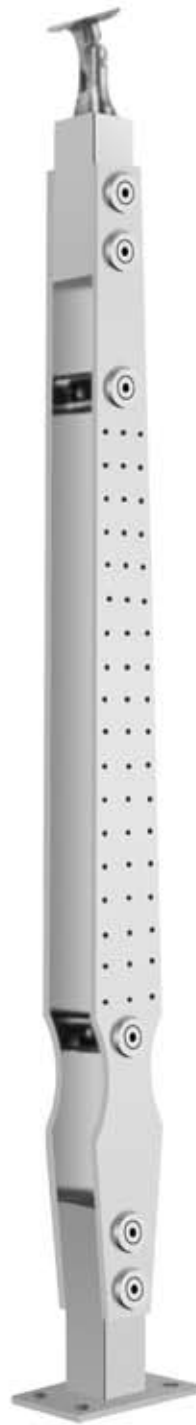

MODEL: 1006

表面处理: 砂光
Finish: Polishing

材质: 不锈钢
Material: stainless steel





MODEL: 1007

表面处理: 砂光
Finish: Polishing

材质: 不锈钢
Material: stainless steel





MODEL: 1008

表面处理: 砂光
Finish: Polishing

材质: 不锈钢
Material: stainless steel



MODEL: 1009

表面处理: 砂光
Finish: Polishing

材质: 不锈钢
Material: stainless steel





MODEL: 1010

表面处理: 砂光
Finish: Polishing
材质: 不锈钢
Material: stainless steel



MODEL: 1011

表面处理: 砂光
Finish: Polishing
材质: 不锈钢
Material: stainless steel





MODEL: 1012

表面处理: 砂光
Finish: Polishing

材质: 不锈钢
Material: stainless steel

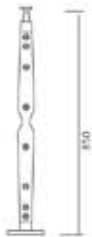



MODEL: 1013

表面处理: 砂光
Finish: Polishing

材质: 不锈钢
Material: stainless steel

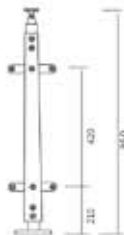

MODEL: 1014

表面处理: 砂光
Finish: Polishing

材质: 不锈钢
Material: stainless steel





MODEL: 1015

表面处理: 砂光
 Finish: Polishing
 材质: 不锈钢
 Material: stainless steel



MODEL: 1016

表面处理: 砂光
 Finish: Polishing
 材质: 不锈钢
 Material: stainless steel

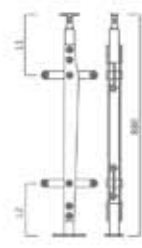

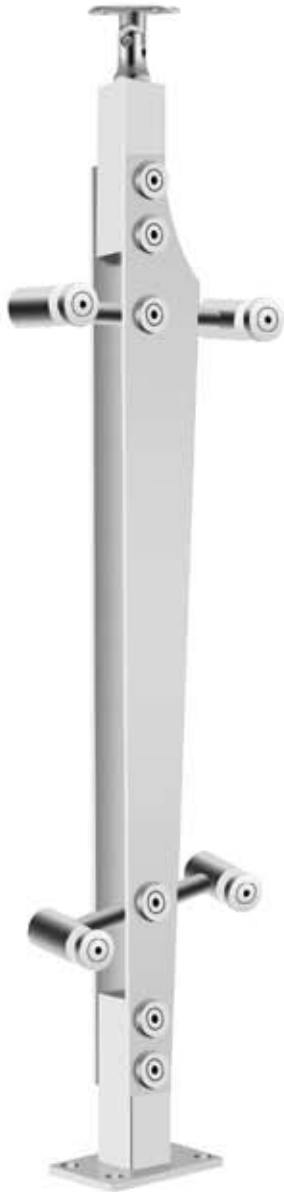

MODEL: 1017

表面处理: 砂光
Finish: Polishing
材质: 不锈钢
Material: stainless steel

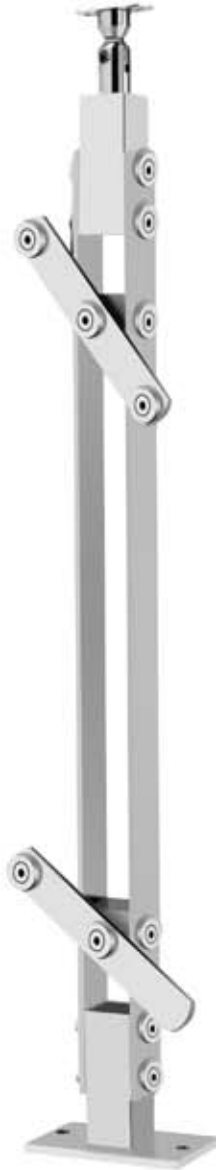
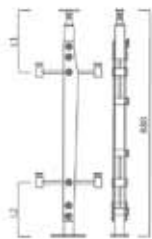

MODEL: 1018

表面处理: 砂光
Finish: Polishing
材质: 不锈钢
Material: stainless steel

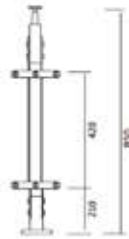

MODEL: 1019

表面处理: 砂光
Finish: Polishing
材质: 不锈钢
Material: stainless steel

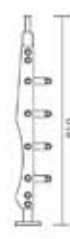



MODEL: 1020

表面处理: 砂光
Finish: Polishing

材质: 不锈钢
Material: stainless steel



MODEL: 1021

表面处理: 砂光
Finish: Polishing

材质: 不锈钢
Material: stainless steel



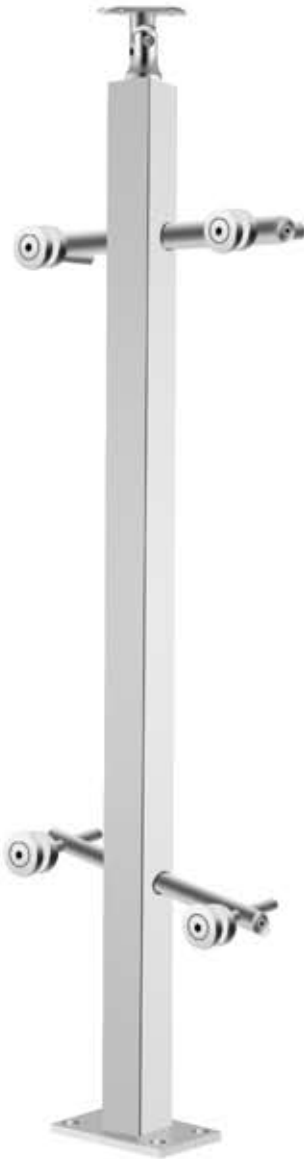

MODEL: 1022

表面处理: 砂光
Finish: Polishing

材质: 不锈钢
Material: stainless steel



MODEL: 1023

表面处理: 砂光
Finish: Polishing

材质: 不锈钢
Material: stainless steel



MODEL: 1024

表面处理: 砂光
Finish: Polishing

材质: 不锈钢
Material: stainless steel

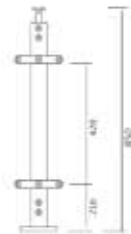



MODEL: 1025

表面处理: 砂光
Finish: Polishing

材质: 不锈钢
Material: stainless steel





MODEL: 1026

表面处理: 砂光
Finish: Polishing

材质: 不锈钢
Material: stainless steel

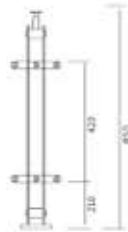

让心灵远离都市的喧哗, 进入忘我的舒适境界, 在这宁静的空气里, 与绿色同鸣, 与自然共醉, 身心疲倦, 瞬间释放。

Keep the heart from the noisy city, enjoy the comfortable atmosphere, in the calm air, Enjoy the green and nature, instantly relax the fatigue physically and mentally



MODEL: 1027

表面处理: 砂光
Finish: Polishing

材质: 不锈钢
Material: stainless steel

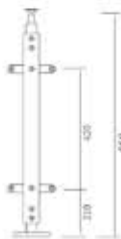

MODEL: 1028

表面处理: 砂光
Finish: Polishing

材质: 不锈钢
Material: stainless steel

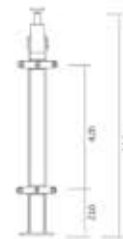



MODEL: 1030

表面处理: 砂光
Finish: Polishing

材质: 不锈钢
Material: stainless steel

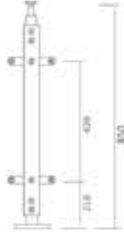

MODEL: 1029

表面处理: 砂光
Finish: Polishing

材质: 不锈钢
Material: stainless steel





MODEL: 1031

表面处理: 砂光
 Finish: Polishing
 材质: 不锈钢
 Material: stainless steel

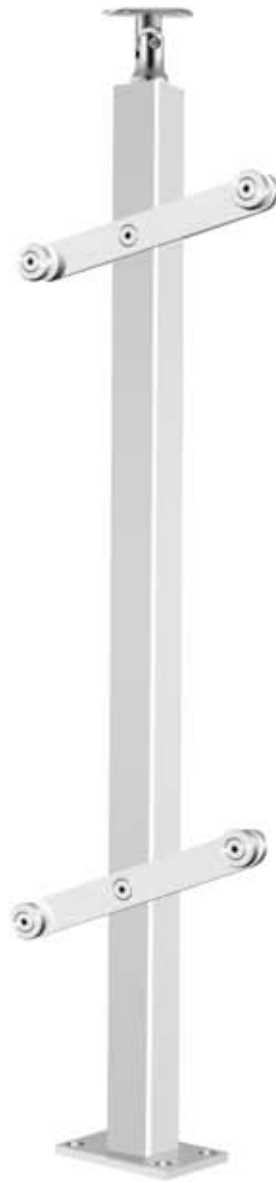

MODEL: 1032

表面处理: 砂光
 Finish: Polishing
 材质: 不锈钢
 Material: stainless steel

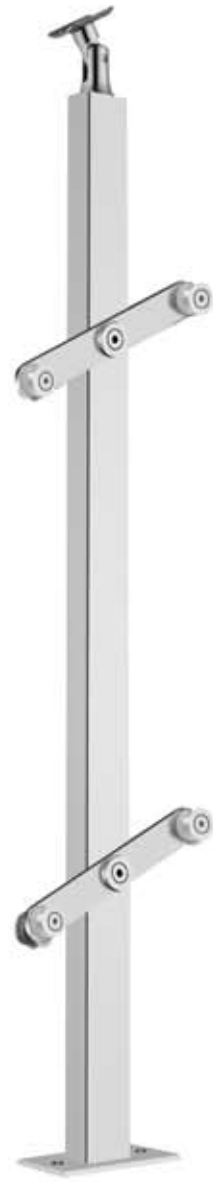
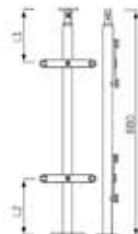

MODEL: 1033

表面处理: 砂光
 Finish: Polishing
 材质: 不锈钢
 Material: stainless steel



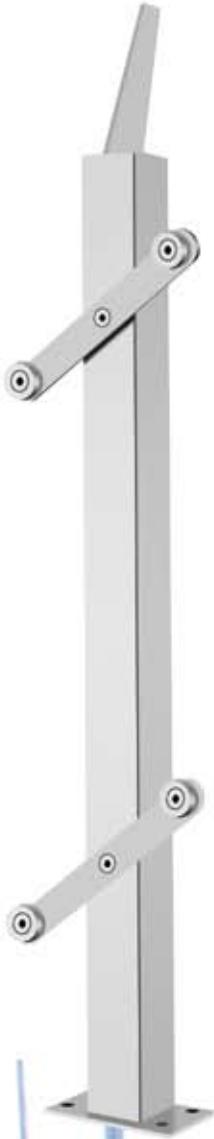

MODEL: 1034

表面处理: 砂光
Finish: Polishing

材质: 不锈钢
Material: stainless steel

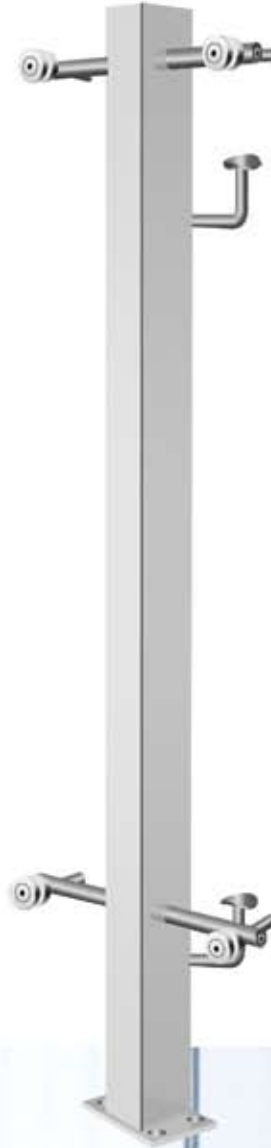
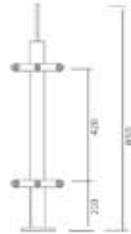

MODEL: 1035

表面处理: 砂光
Finish: Polishing

材质: 不锈钢
Material: stainless steel

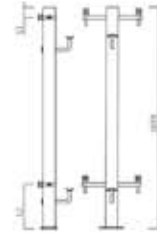

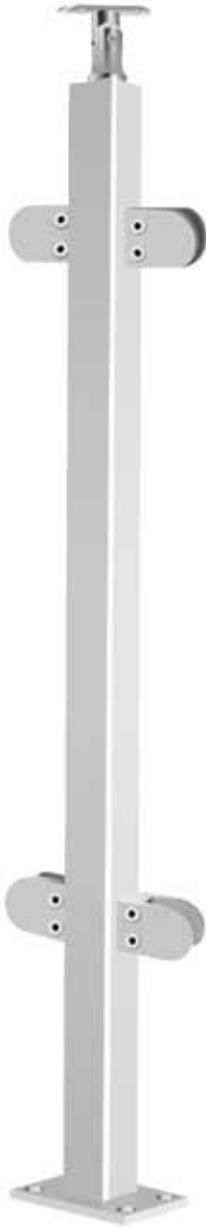

MODEL: 1036

表面处理: 砂光
 Finish: Polishing

材质: 不锈钢
 Material: stainless steel

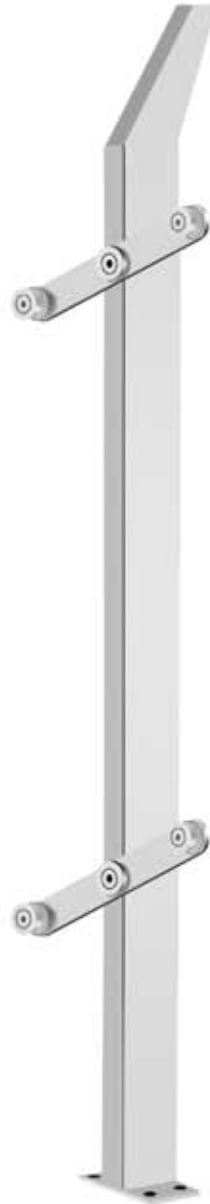

MODEL: 1037

表面处理: 砂光
 Finish: Polishing

材质: 不锈钢
 Material: stainless steel

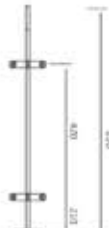

MODEL: 1038

表面处理: 砂光
 Finish: Polishing

材质: 不锈钢
 Material: stainless steel



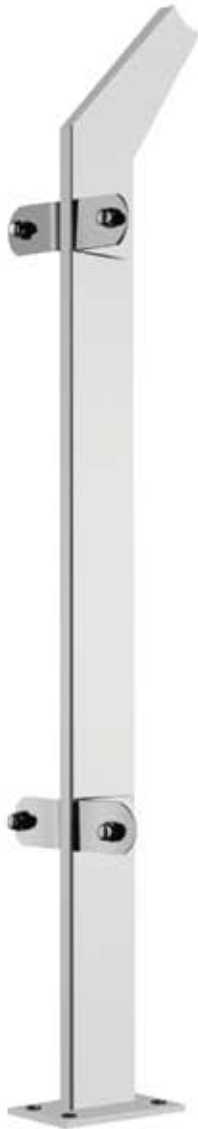

MODEL: 1039

表面处理: 砂光
Finish: Polishing

材质: 不锈钢
Material: stainless steel



MODEL: 1040

表面处理: 砂光
Finish: Polishing

材质: 不锈钢
Material: stainless steel



MODEL: 1041

表面处理: 砂光
Finish: Polishing

材质: 不锈钢
Material: stainless steel





MODEL: 1042

表面处理: 砂光
Finish: Polishing

材质: 不锈钢
Material: stainless steel

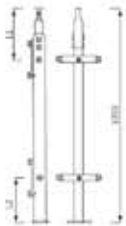

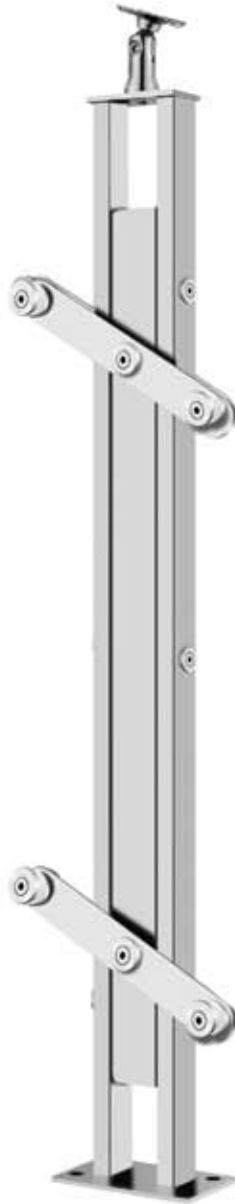

MODEL: 1043

表面处理: 砂光
Finish: Polishing

材质: 不锈钢
Material: stainless steel

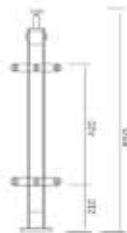

MODEL: 1044

表面处理: 砂光
Finish: Polishing

材质: 不锈钢
Material: stainless steel

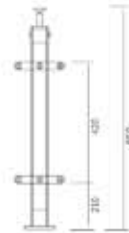



MODEL: 1045

表面处理: 砂光
Finish: Polishing
材质: 不锈钢
Material: stainless steel

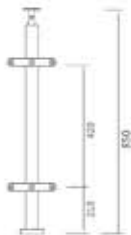

MODEL: 1046

表面处理: 砂光
Finish: Polishing
材质: 不锈钢
Material: stainless steel



MODEL: 1047

表面处理: 砂光
Finish: Polishing
材质: 不锈钢
Material: stainless steel





Stainless steel Series 不锈钢系列(工程柱系列)

刚毅礼赞，大海情怀，一如不锈钢果敢气度；明静如镜，淳朴如情，不锈钢另一面的温情气质。
花月佳期下，人有约，月有情，绵延诗情画意的时光。

Supper praise,and the sea feelings,as stainless steel bold temperament;cleaning as a mirror,simple as intelligence,stainless steel warmth another side of temperament.Perfect spent on ,some people,of feelings, or of extending time.

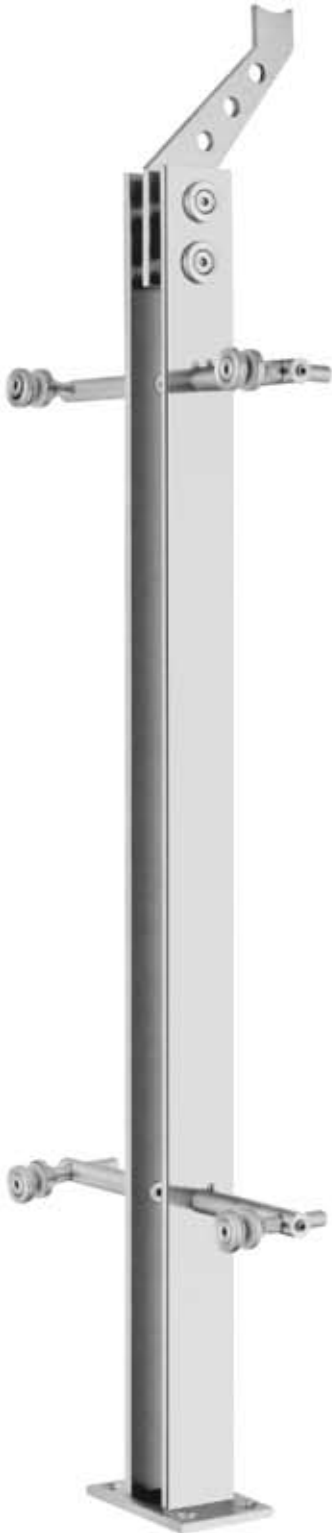

拥有精深博学的才华，才会懂得欣赏艺术，懂得欣赏艺术，才能体会其价值所在。

Only possession of intensive and erudite talent will people know how to appreciate art, and only knowing how to appreciate art will people realize its value.

MODEL: 1048

表面处理: 砂光
Finish: Polishing

材质: 不锈钢
Material: stainless steel



MODEL: 1049
表面处理: 砂光
Finish: Polishing
材质: 不锈钢
Material: stainless steel

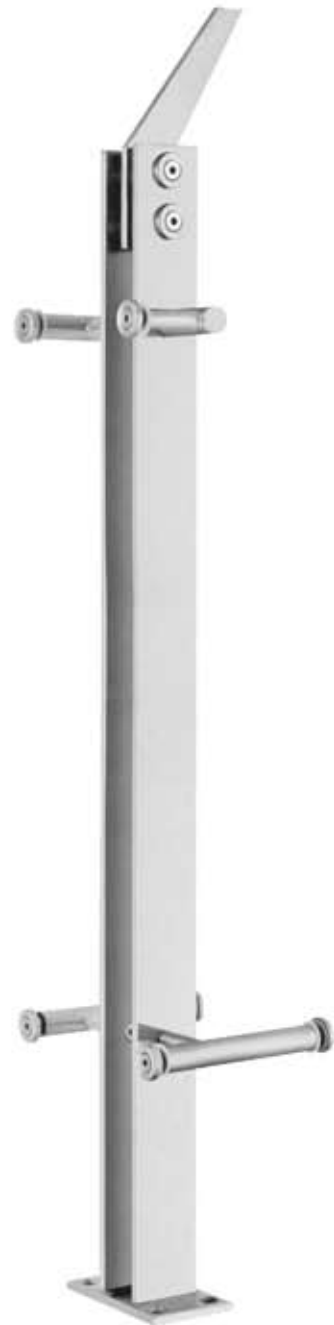

MODEL: 1050
表面处理: 砂光
Finish: Polishing
材质: 不锈钢
Material: stainless steel



MODEL: 1051
表面处理: 砂光
Finish: Polishing
材质: 不锈钢
Material: stainless steel



MODEL: 1052
表面处理: 砂光
Finish: Polishing
材质: 不锈钢
Material: stainless steel





MODEL: 1053

表面处理: 砂光
Finish: Polishing
材质: 不锈钢
Material: stainless steel

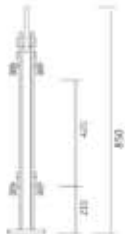

MODEL: 1054

表面处理: 砂光
Finish: Polishing
材质: 不锈钢
Material: stainless steel



MODEL: 1055

表面处理: 砂光
Finish: Polishing
材质: 不锈钢
Material: stainless steel

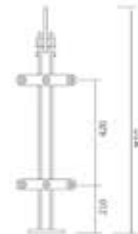



MODEL: 1056

表面处理: 砂光
Finish: Polishing

材质: 不锈钢
Material: stainless steel



MODEL: 1057

表面处理: 砂光
Finish: Polishing

材质: 不锈钢
Material: stainless steel



MODEL: 1058

表面处理: 砂光
Finish: Polishing

材质: 不锈钢
Material: stainless steel





MODEL: 1059

表面处理: 砂光
Finish: Polishing
材质: 不锈钢
Material: stainless steel



MODEL: 1060

表面处理: 砂光
Finish: Polishing
材质: 不锈钢
Material: stainless steel



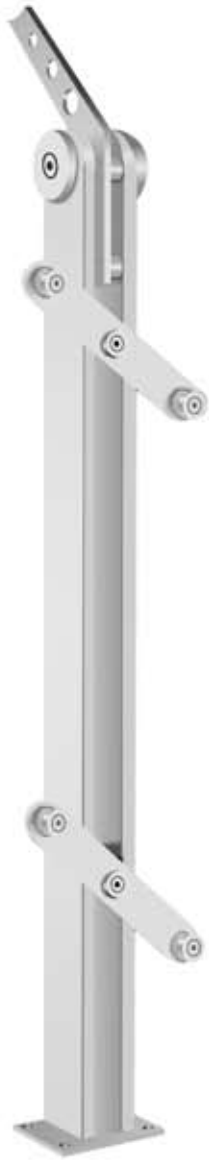

MODEL: 1061

表面处理：砂光
Finish: Polishing

材质：不锈钢
Material: stainless steel

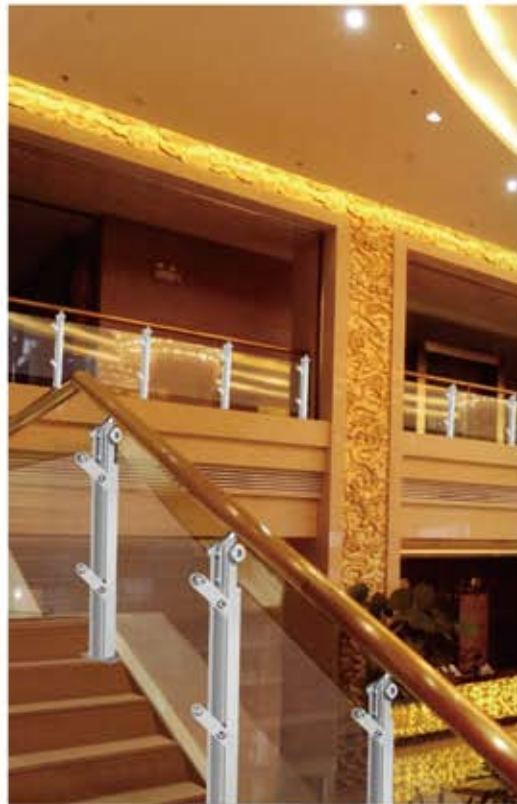

MODEL: 1062

表面处理：砂光
Finish: Polishing

材质：不锈钢
Material: stainless steel

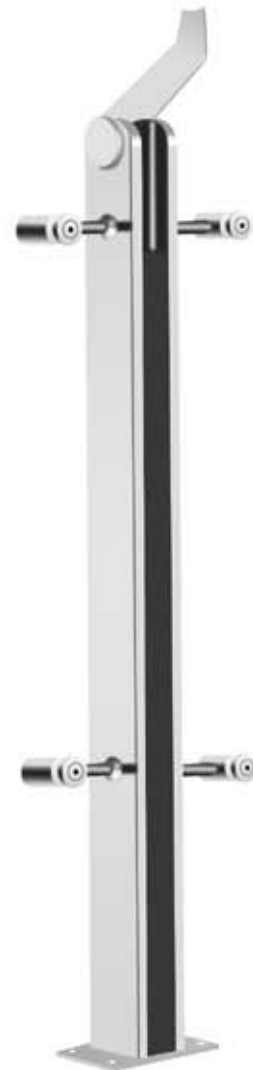



MODEL: 1063

表面处理: 砂光
Finish: Polishing

材质: 不锈钢
Material: stainless steel

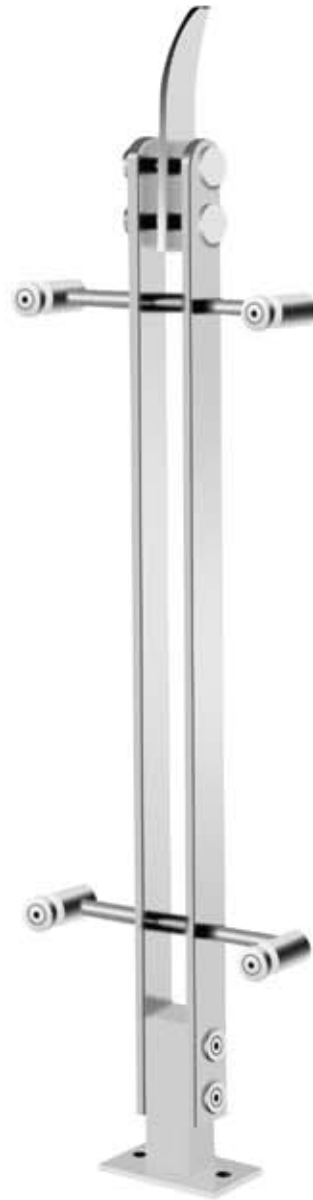
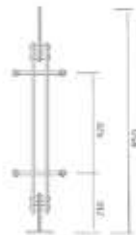

MODEL: 1064

表面处理: 砂光
Finish: Polishing

材质: 不锈钢
Material: stainless steel

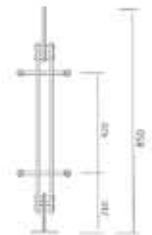



MODEL: 1065

表面处理: 砂光
 Finish: Polishing
 材质: 不锈钢
 Material: stainless steel



MODEL: 1066

表面处理: 砂光
 Finish: Polishing
 材质: 不锈钢
 Material: stainless steel



MODEL: 1067

表面处理: 砂光
 Finish: Polishing
 材质: 不锈钢
 Material: stainless steel



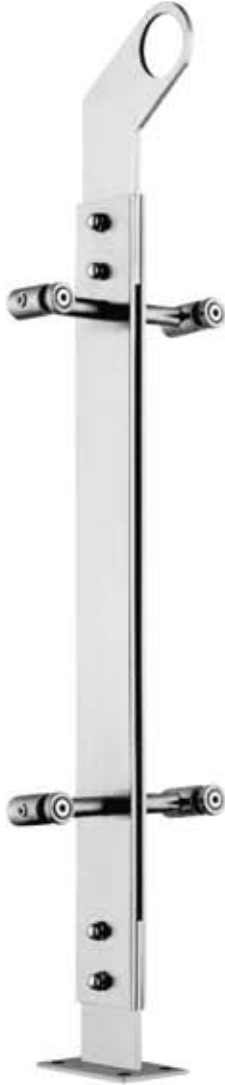

MODEL: 1068

表面处理: 砂光
Finish: Polishing
材质: 不锈钢
Material: stainless steel

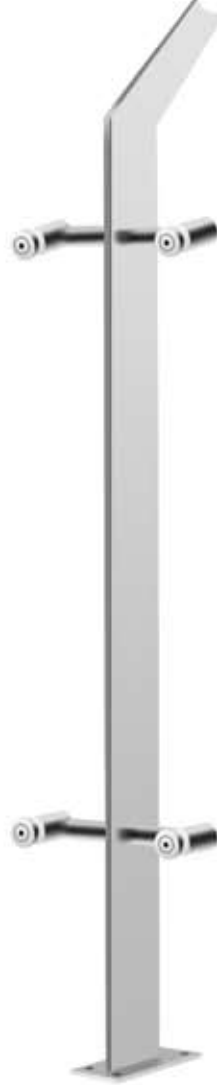

MODEL: 1069

表面处理: 砂光
Finish: Polishing
材质: 不锈钢
Material: stainless steel

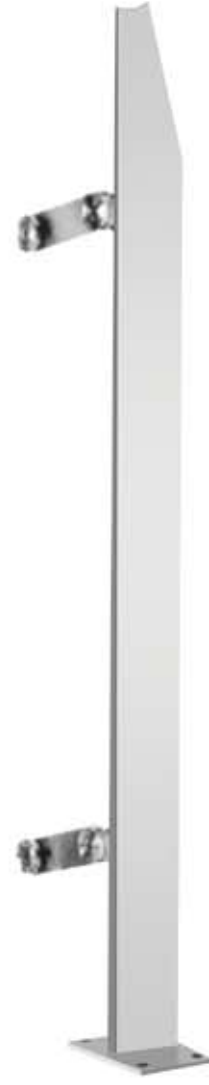

MODEL: 1070

表面处理: 砂光
Finish: Polishing
材质: 不锈钢
Material: stainless steel





MODEL: 1071

表面处理: 砂光
Finish: Polishing

材质: 不锈钢
Material: stainless steel



MODEL: 1072

表面处理: 砂光
Finish: Polishing

材质: 不锈钢
Material: stainless steel



MODEL: 1073

表面处理: 砂光
Finish: Polishing

材质: 不锈钢
Material: stainless steel





MODEL: 1074

表面处理: 砂光
Finish: Polishing

材质: 不锈钢
Material: stainless steel

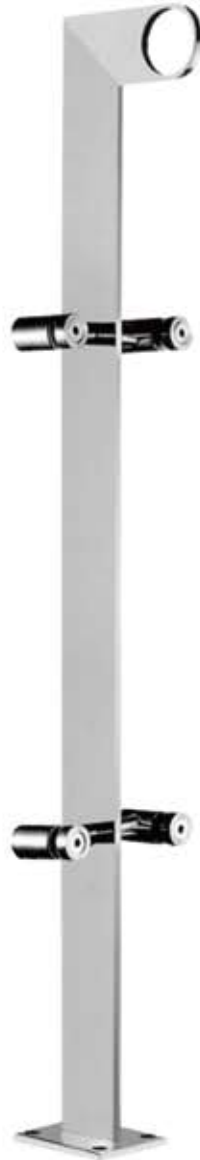

MODEL: 1075

表面处理: 砂光
Finish: Polishing

材质: 不锈钢
Material: stainless steel





MODEL: 1076
表面处理: 砂光
Finish: Polishing
材质: 不锈钢
Material: stainless steel



MODEL: 1077
表面处理: 砂光
Finish: Polishing
材质: 不锈钢
Material: stainless steel

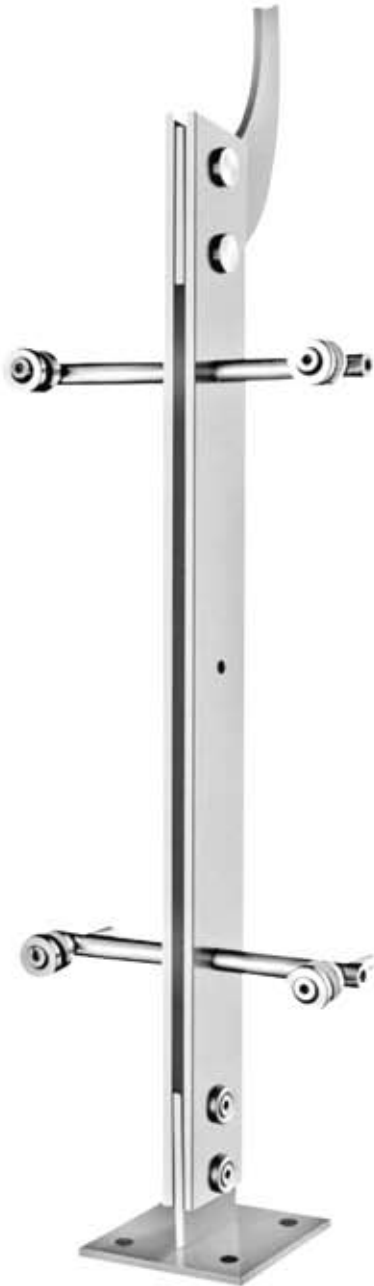

MODEL: 1078

表面处理: 砂光
Finish: Polishing

材质: 不锈钢
Material: stainless steel



MODEL: 1079

表面处理: 砂光
Finish: Polishing

材质: 不锈钢
Material: stainless steel



MODEL: 1080

表面处理：砂光
Finish: Polishing
材质：不锈钢
Material: stainless steel



MODEL: 1081

表面处理：砂光
Finish: Polishing
材质：不锈钢
Material: stainless steel



MODEL: 1082

表面处理：砂光
Finish: Polishing
材质：不锈钢
Material: stainless steel



MODEL: 1083

表面处理: 砂光
Finish: Polishing
材质: 不锈钢
Material: stainless steel

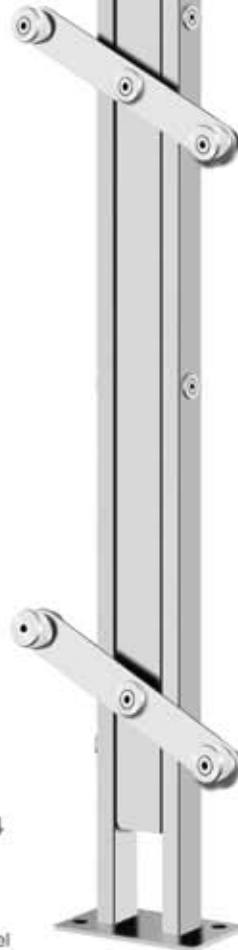

MODEL: 1084

表面处理: 砂光
Finish: Polishing
材质: 不锈钢
Material: stainless steel



MODEL: 1085

表面处理: 砂光
 Finish: Polishing
 材质: 不锈钢
 Material: stainless steel



MODEL: 1086

表面处理: 砂光
 Finish: Polishing
 材质: 不锈钢
 Material: stainless steel

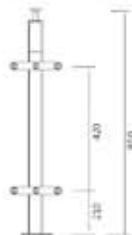

MODEL: 1087

表面处理: 砂光
 Finish: Polishing
 材质: 不锈钢
 Material: stainless steel



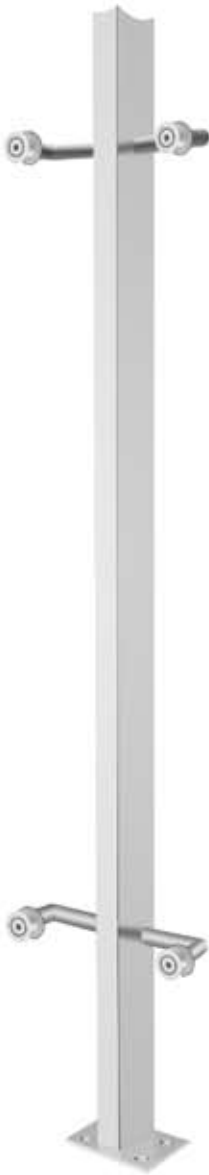

MODEL: 1088

表面处理: 砂光
Finish: Polishing
材质: 不锈钢
Material: stainless steel

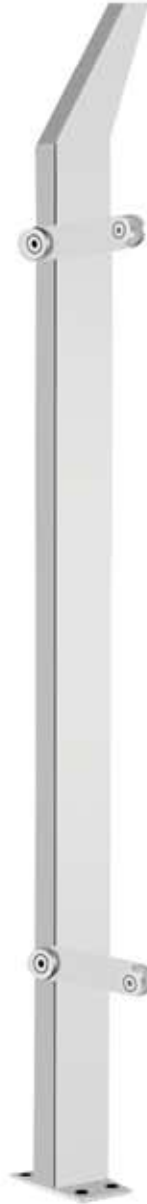

MODEL: 1089

表面处理: 砂光
Finish: Polishing
材质: 不锈钢
Material: stainless steel



MODEL: 1090

表面处理: 砂光
Finish: Polishing
材质: 不锈钢
Material: stainless steel





MODEL: 1091

表面处理: 砂光
Finish: Polishing

材质: 不锈钢
Material: stainless steel



MODEL: 1092

表面处理: 砂光
Finish: Polishing

材质: 不锈钢
Material: stainless steel

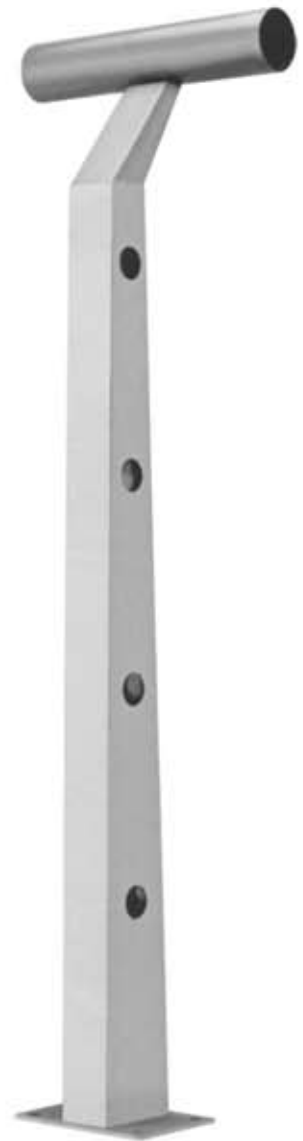

MODEL: 1093

表面处理: 砂光
Finish: Polishing

材质: 不锈钢
Material: stainless steel



MODEL: 1094

表面处理: 砂光
Finish: Polishing
材质: 不锈钢
Material: stainless steel



MODEL: 1095

表面处理: 砂光
Finish: Polishing
材质: 不锈钢
Material: stainless steel



MODEL: 1096

表面处理: 砂光
Finish: Polishing
材质: 不锈钢
Material: stainless steel



MODEL: 1097

表面处理: 砂光
Finish: Polishing

材质: 不锈钢
Material: stainless steel



MODEL: 1098

表面处理: 砂光
Finish: Polishing

材质: 不锈钢
Material: stainless steel



MODEL: 1099

表面处理: 砂光
Finish: Polishing

材质: 不锈钢
Material: stainless steel



MODEL: 1100

表面处理: 砂光
Finish: Polishing

材质: 不锈钢
Material: stainless steel



MODEL: 1101

表面处理: 砂光
Finish: Polishing

材质: 不锈钢
Material: stainless steel



MODEL: 1102

表面处理: 砂光
Finish: Polishing

材质: 不锈钢
Material: stainless steel

以专业引领科技，以科技成就专业
To professional lead technology
Professional science and technology achievements



MODEL: 1103

表面处理: 砂光
Finish: Polishing

材质: 不锈钢
Material: stainless steel



MODEL: 1104

表面处理: 砂光
Finish: Polishing

材质: 不锈钢
Material: stainless steel

护栏 / 阳台 / 扶手配件系列

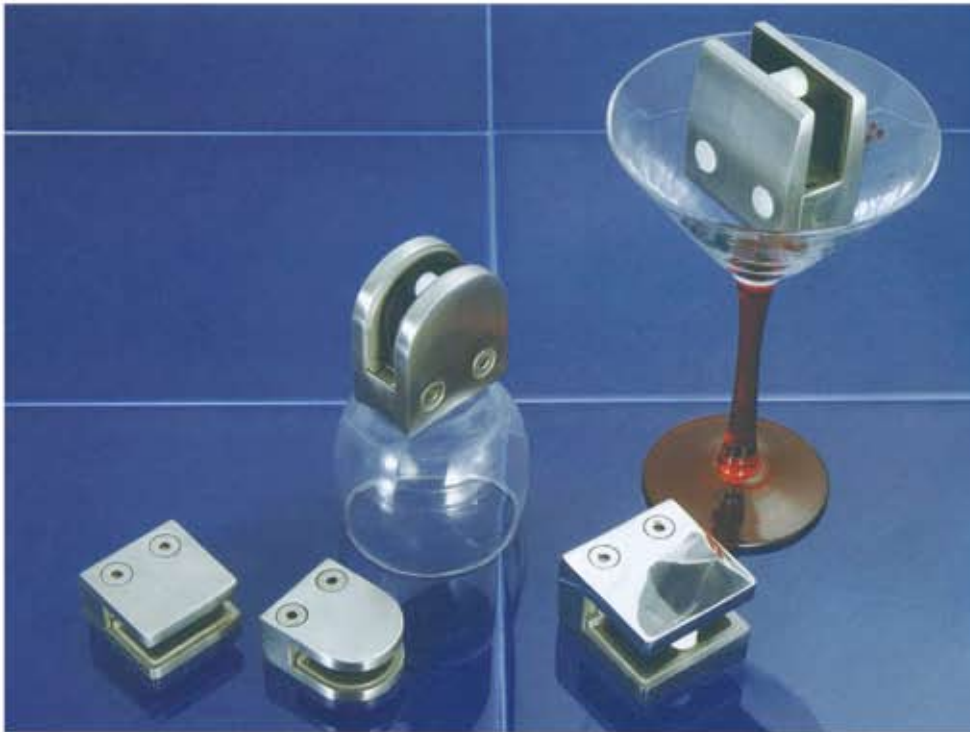

护栏 / 阳台 / 扶手配件系列

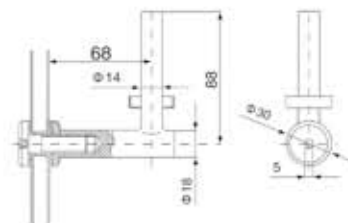
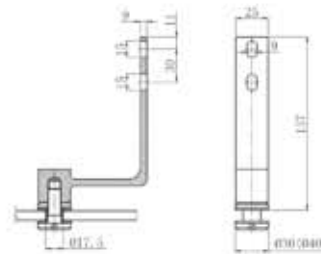
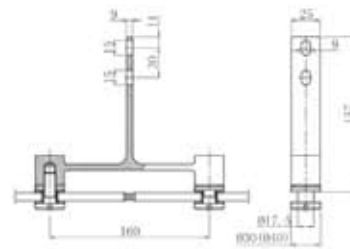
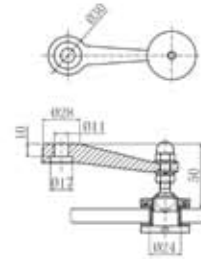

护栏 / 阳台 / 扶手配件系列

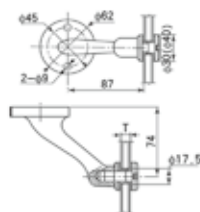
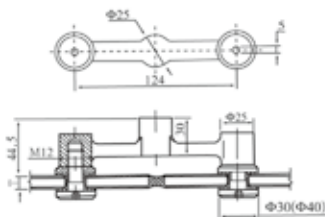
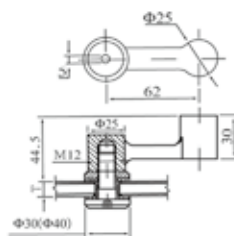
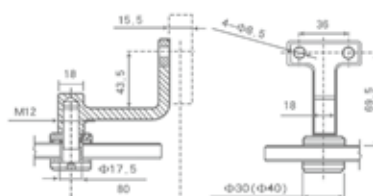
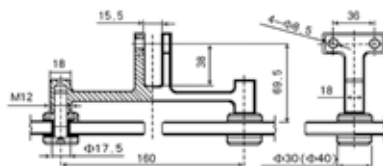

 实心沉头垫片 P-15	 玻璃夹 P-16	 玻璃夹 P-17	 玻璃夹 P-18	 玻璃夹 P-19
 广告钉 P-20	 P-21	 P-22	 P-23	 空心广告钉 P-24
 空心广告钉 P-25	 耳搭片 P-26	 耳搭片 P-27	 耳搭片 P-28	 耳搭片 P-29
 耳搭片 P-30	 空心沉头垫片 P-31	 空心沉头垫片 P-32	 六角盖帽 P-33	 六角盖帽 P-34
 立柱挂件 P-35	 堵头、接头 P-36	 P-37	 P-38	
 双牙 P-39	 P-40	 P-41	 P-42	 P-43



闷帽

P-44



P-45



脚夹帽

P-46



P-47



P-48



P-49



P-50



P-51



P-52



P-53



P-54



P-55



P-56



P-57



P-58



P-59



P-60



P-61



P-62



P-63



P-64



P-65



P-66



P-67



P-68



P-69



P-70



P-71



Φ60 封头

P-72

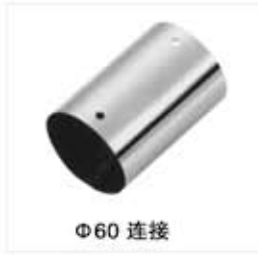

Φ60 连接

P-73



PVC 色板系列



泳池玻璃夹系列



Y01



Y02



Y03



Y04



泳池玻璃夹系列



Y05



Y06

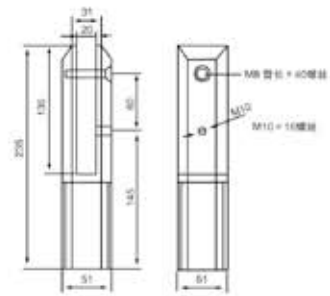

Y07

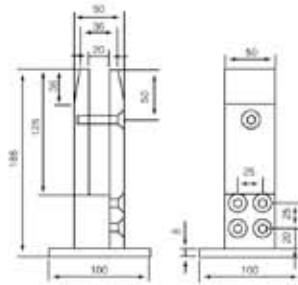

Y08

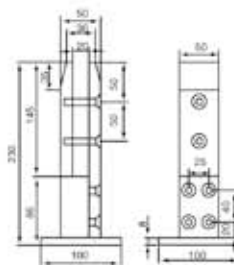

泳池玻璃夹系列



工程案例

160 驳接爪系列



1601

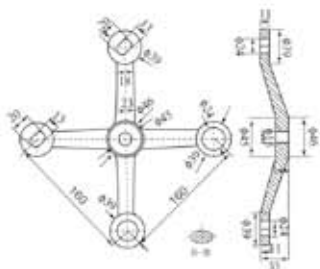

1602

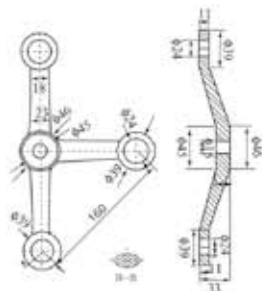

1603

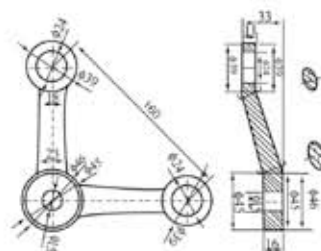

1604

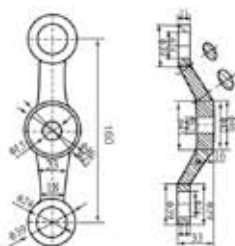

1605

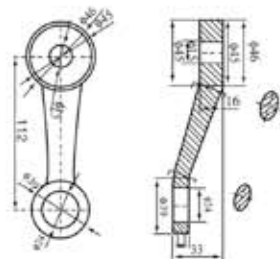

1606

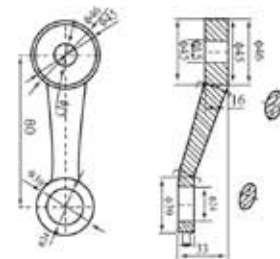

220 驳接爪系列



2201

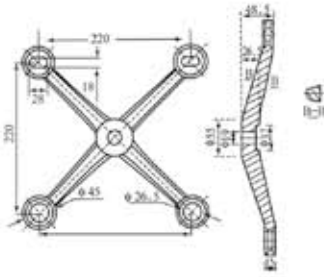

2202

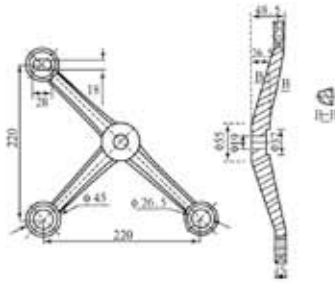

2203

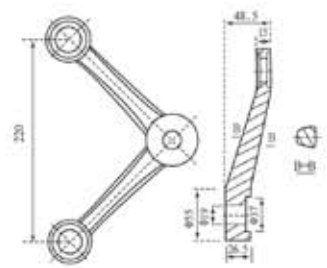

2204

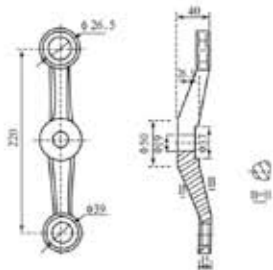

2205

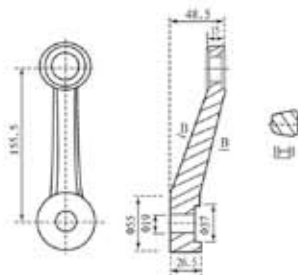

2206

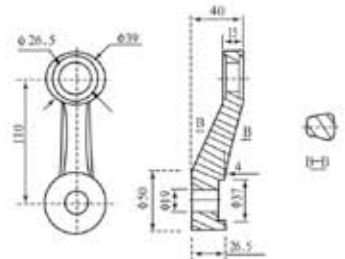

250 驳接爪系列



2501

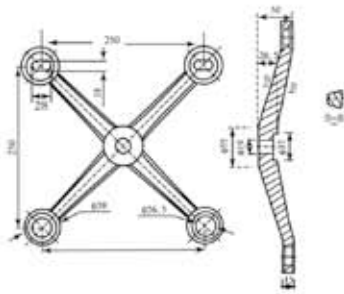

2502

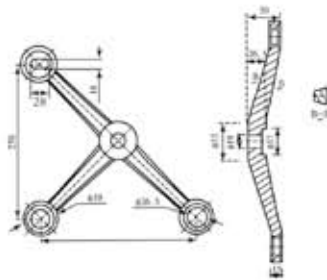

2503

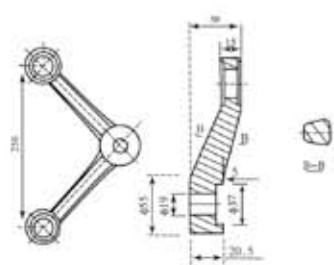

2504

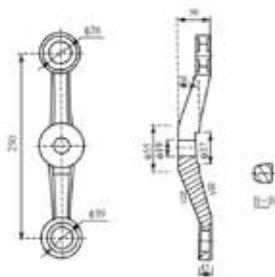

2505

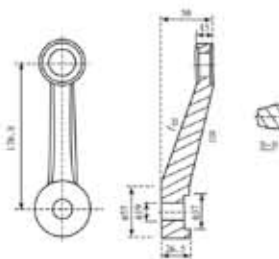

2506

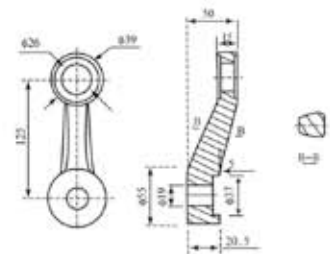

2540 驳接爪系列



25401

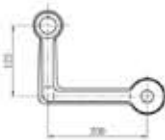
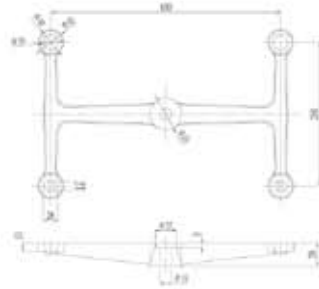

25402

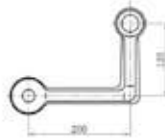

25403

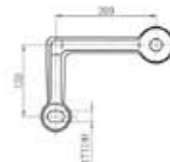

25404

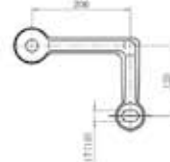

25405

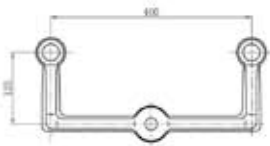

25406



25407

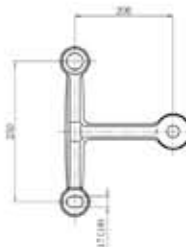

25408

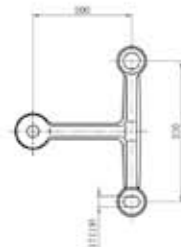

25409

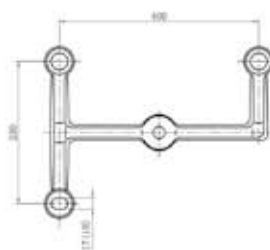

254010

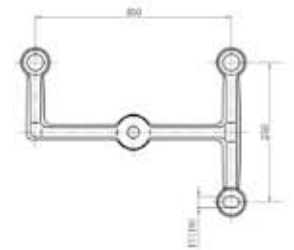

254011

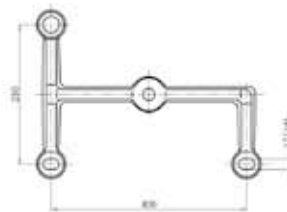

254012

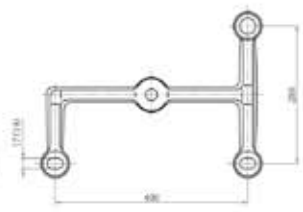

254013

3060 驳接爪系列



30601

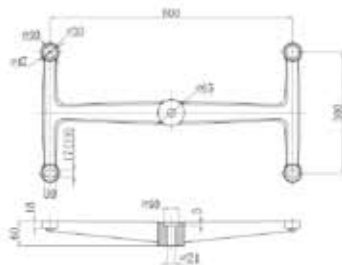

30602

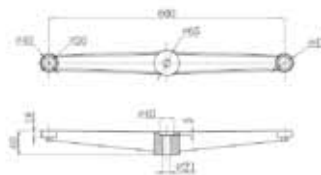

30603

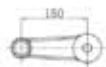

30605

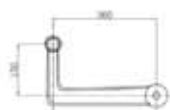

30607

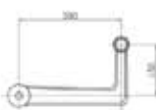

30608

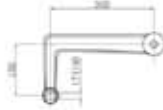

30609

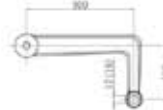

30610



30604

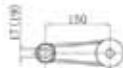

30606



306011



306012

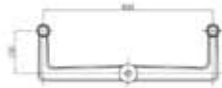

306013



306014

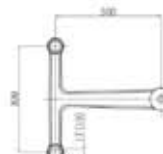

306015

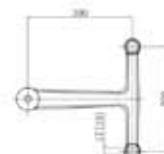

306016

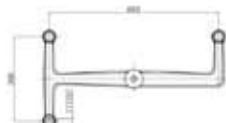

306017

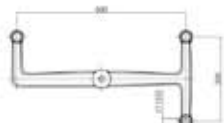

306018

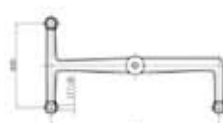

306019

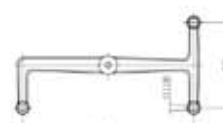

306020

3535 驳接爪系列



335351

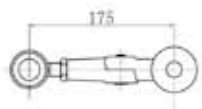
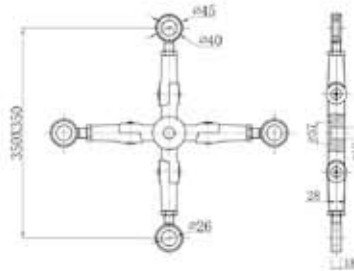

335352

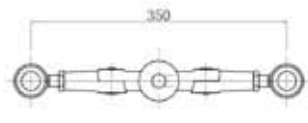

335353

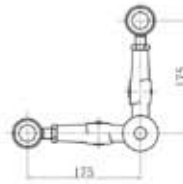

335354

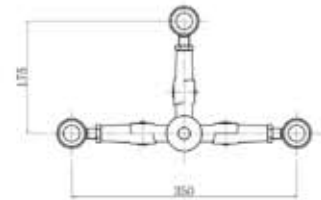

335355

W300 驳接爪系列



W3001

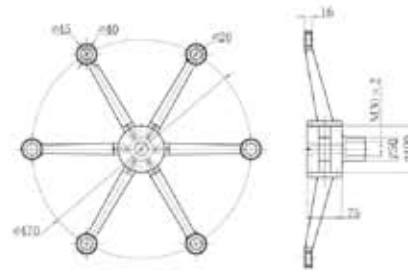

W3002

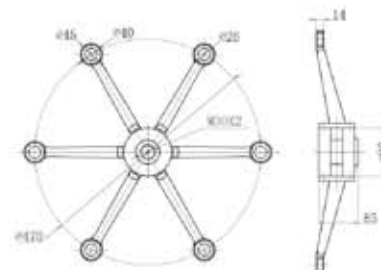

玻璃肋端夹板系列



LB01

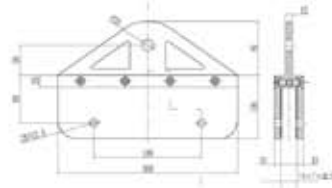

LB02

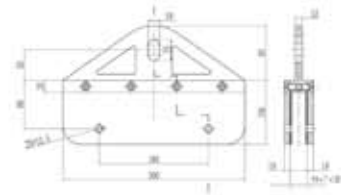

LB03

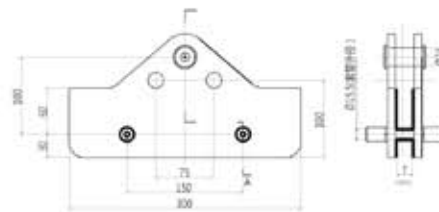

LB04

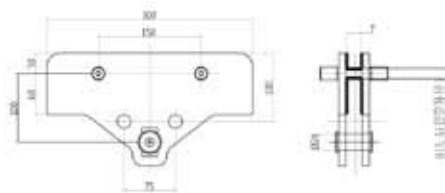

K 爪系列肋驳爪



以规模取效益 >>>
Profit acquirement by scale

以质量立信誉 >>>
Credit establishment by quality

驳接头系列



T01



T02



T03



T04

玻璃夹系列



BL-1



BL-2



BL-3



BL-4

玻璃吊夹系列



J-1



J-2



J-3



J-4

索锚具系列

悬索式系统标准件

悬索式系统产品主要由驳接爪、钢索夹、钢索拉头组件及悬空杆组成空间桁架，索桁架要悬挂在支承结构上进行拉紧，施加适当的预应力，才能形成固定形状的钢架桁架来承受外荷载的结构。



图1



图2

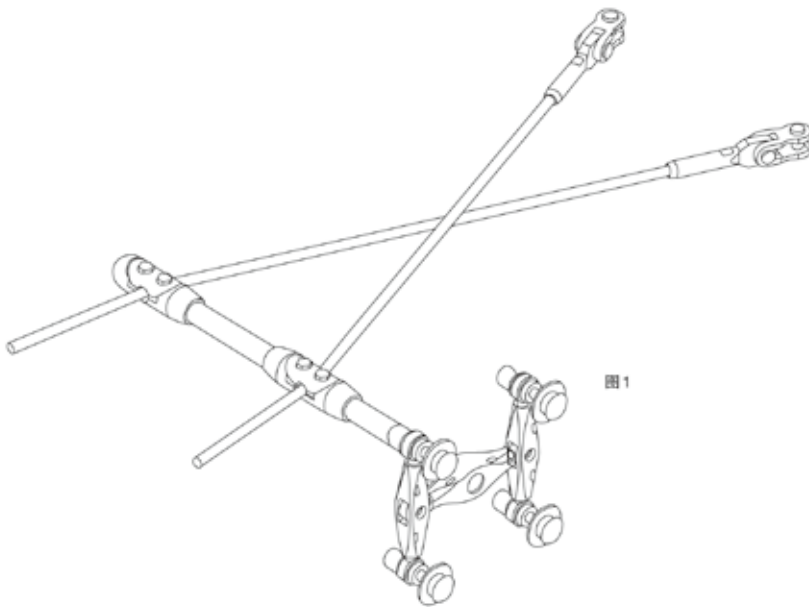

图3

图1. 悬索式系统标准示意图
图2. 中置钢索铁轴测示意图
图3. 终端钢索铁轴测示意图

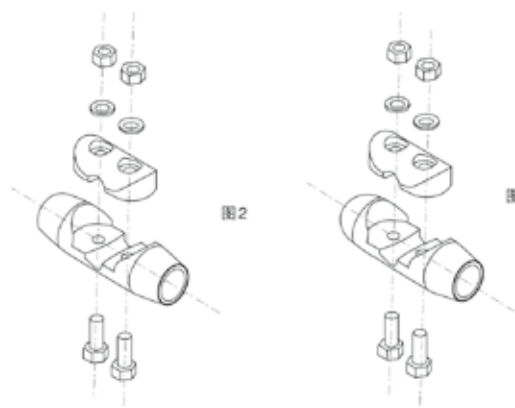
拉杆系列

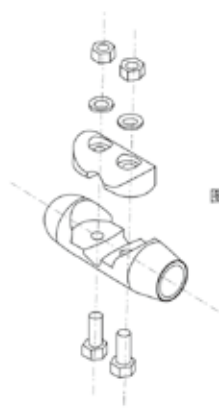

不锈钢拉杆截面力学性能(材质：316)

The section area and mechanics capability of stainless steel rob.(Material S.S 316)

序号	杆端螺纹 (mm)	拉杆有效截面积 (mm ²)	拉杆截面积 (mm ²)	屈服强度 _{0.2} (MPa)	抗拉强度 _b (MPa)	拉伸率 (%)
1	M8	33.183	50.265	205	520	25
2	M10	52.180	78.540			
3	M12	78.540	113.097			
4	M14	103.869	153.938			
5	M16	143.139	201.062			
6	M18	176.715	245.469			
7	M20	226.980	314.159			
8	M22	283.529	380.133			
9	M24	380.133	452.390			
10	M27	510.705	615.752			
11	M30	572.555	706.858			
12	M33	683.493	804.248			
12	M36	804.248	1017.876			
14	M39	1017.876	1194.591			

拉杆系列

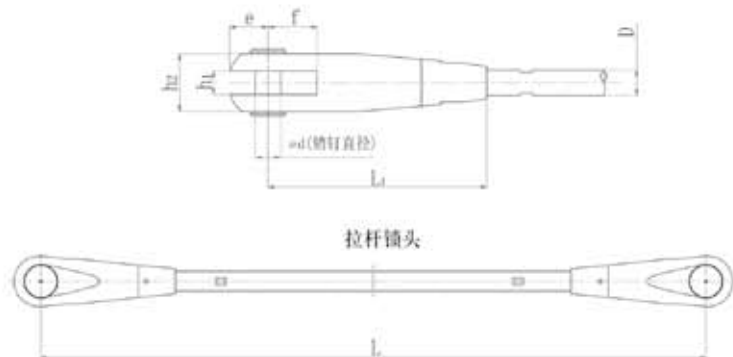

型号 S/N	螺纹直径 Thread d	d	e	f	h_1	h_2	L_1	d	单边调节量 Variable length
F01-10	M10	10	18	23	11	26.5	100	12	± 12.5
F02-12	M12	12	18	23	11	26.5	100	12	± 12.5
F03-14	M14	14	20	25	13	31	108	14	± 12.5
F04-16	M16	16	23	28	15	35	117	16	± 12.5
F05-18	M18	18	25	35	17	40	130	18	± 12.5
F06-20	M20	20	30	35	17	42.5	138	20	± 14
F07-22	M22	22	32	42	21	47	148	22	± 14
F08-24	M24	24	38	48	21	53	170	24	± 15
F09-27	M27	27	42	52	25	60	182	27	± 15
F10-30	M30	30	45	60	25	65	195	30	± 15
F11-33	M33	33	49.0	65	27	68	205	32	± 17.5
F12-36	M36	36	56.0	72	29	76	220	36	± 17.5
F13-39	M39	39	61.0	80	33	85	250	39	± 17.5

拉索系列

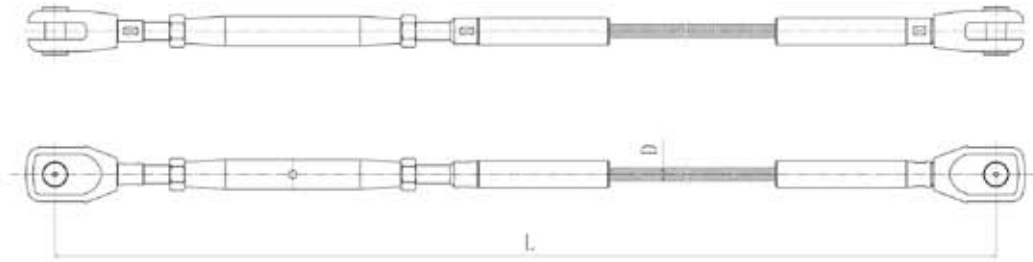

用户在订购产品时,其长度应为如图中两销钉中心距的尺寸。

压制头拉索截面参数与力学性能(材质:316)
Parameters and mechanical properties of swaged end cable

钢索直径(mm) Cable Diameter(mm)	参考结构 Reference Configuration	钢丝直径(mm) Steel Wire Diameter(mm)	金属断面积(mm ²) Sectional Area(mm ²)	钢索最小破断拉力(kN) Minimum Breaking Strength(kN)	弹性模量(10 ⁵ N/mm ²) Modules Elasticity(10 ⁵ N/mm ²)
6	1 × 19	1.20	21.48	25.53	1.30 ± 0.10
8		1.60	38.20	43.87	
10		2.00	59.69	68.55	
12		2.40	85.95	98.71	
14		2.80	116.99	134.35	
16		3.20	152.81	175.48	
16	1 × 37	2.29	152.39	175.00	
18		2.57	192.15	218.16	
20		2.86	237.22	269.33	
22	1 × 61	2.44	286.27	325.02	
24		2.67	340.69	386.80	
26		2.89	399.84	453.95	
28		3.11	463.71	526.48	
30	1 × 91	2.73	531.60	603.56	
32		2.91	604.85	686.71	
34		3.09	682.82	775.24	
36		3.27	765.51	869.12	

拉索系列

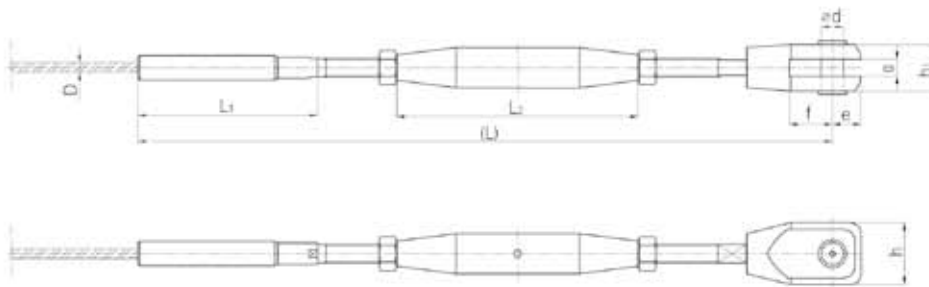

D	(L)mm	L ₁	L ₂	d ∅	g	h ₁	f	e	h
∅6	410~535	85	210	14.5	11	35	30	25	46
∅8	416~540	105	210	14.5	11	35	30	25	46
∅10	495~616	135	230	16	15	42	32	28	55
∅12	544~700	150	250	20	17	44	32	28	59
∅14	598~759	176	260	22	21	50	38	34	59
∅16	645~820	190	290	27.5	23	55	42	38	65
∅18	720~905	213	320	27.5	25	60	46	40	72
∅19.5	742~918	235	320	30.5	25	60	46	40	72
∅21	752~928	245	320	30.5	25	60	46	40	72

拉索系列

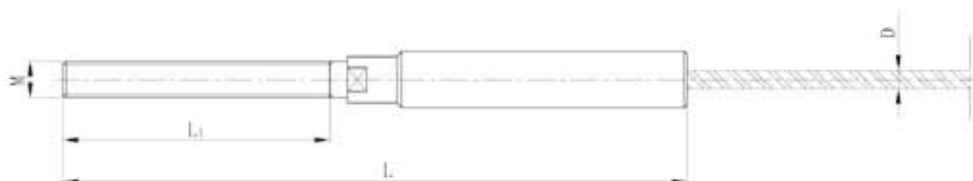

D	L ₁	L	M
∅6	100	185	M12
∅8	110	215	M14
∅10	120	253	M16
∅12	130	292	M20
∅14	135	311	M22
∅16	150	340	M27
∅18	160	373	M30
∅19.5	170	401	M30
∅21	180	415	M33

D	L ₁	L	M
∅22.5	167	461	M33
∅24	182	496	M36
∅26	196	521	M39
∅28	206	552	M42
∅30	222	596	M45
∅32	232	633	M48
∅34	255	678	M52
∅36	268	713	M56

拉索系列

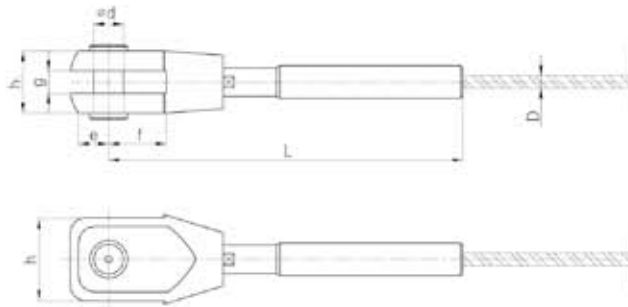

D	L	∅d	g	h ₁	e	f	h
∅6	142	14.5	11	35	25	30	46
∅8	148	14.5	11	35	25	30	46
∅10	197	16	15	42	28	32	55
∅12	234	20	17	44	28	32	57
∅14	253	22	21	50	34	38	59
∅16	272	27.5	23	55	38	42	65
∅18	305	27.5	25	60	40	46	72
∅19.5	316	30.5	25	60	40	46	72
∅21	327	30.5	25	60	40	46	72
∅22.5	375	36	28	72	46	60	92
∅24	390	37	32	78	52	60	95
∅26	430	41	32	82	56	70	103
∅28	462	44	36	94	60	72	109
∅30	495	49	42	106	77	92	125
∅32	525	53	43	112	82	102	128
∅34	565	56	46	119	88	108	135
∅36	595	59	48	126	92	114	145
∅40	640	62	50	128	95	120	162

拉索系列

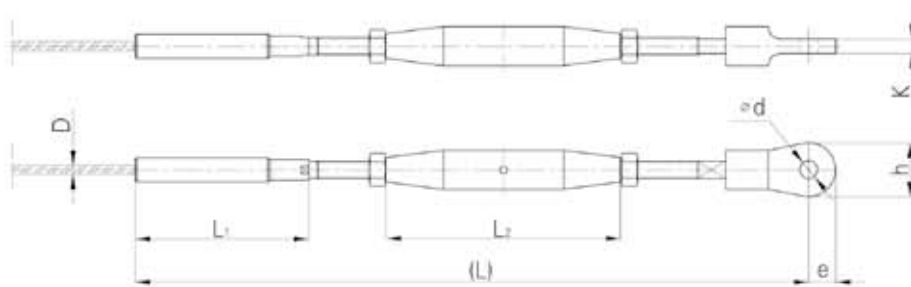

D	(L)mm	L ₁	L ₂	ød	k	e	h
ø6	381~457	115	145	14.5	10	18	36
ø8	424~514	130	145	14.5	12	20	40
ø10	476~585	140	165	16.5	14	23	46
ø12	546~672	160	180	18.5	16	30	60
ø14	592~722	180	210	22.5	20	35	70
ø16	684~840	200	230	27.5	22	40	80
ø18	750~927	220	250	30.5	28	38	76
ø19.5	775~952	245	260	30.5	28	38	76
ø21	840~1036	261	290	33.5	28	40	80

拉索系列

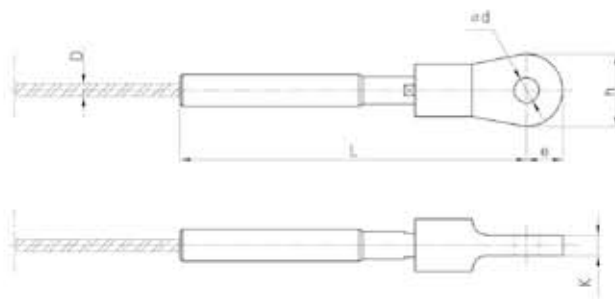

D	L	ød	e	k	h
ø 6	175	12.5	18	10	36
ø 8	195	14.5	20	12	40
ø 10	213	16.5	23	14	46
ø 12	246	18.5	30	16	60
ø 14	277	22.5	35	20	70
ø 16	313	27.5	40	22	80
ø 18	345	30.5	38	28	76
ø 19.5	370	30.5	38	28	76
ø 21	396	33.5	40	28	80

窨井盖系列



窨井盖系列

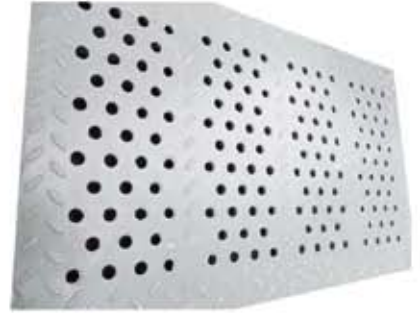

窨井盖实例图系列

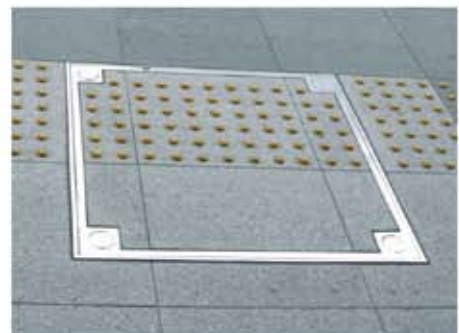

不锈钢井盖、 格栅、 水沟盖板系列

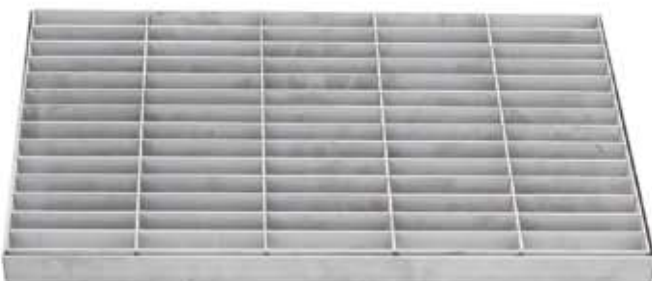
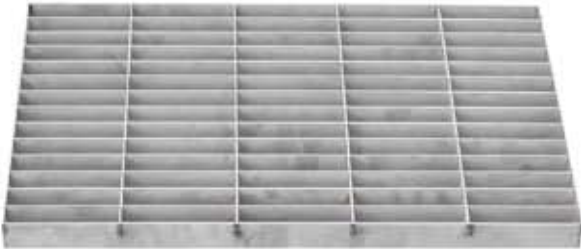
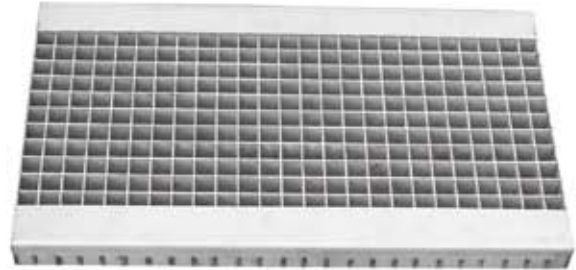
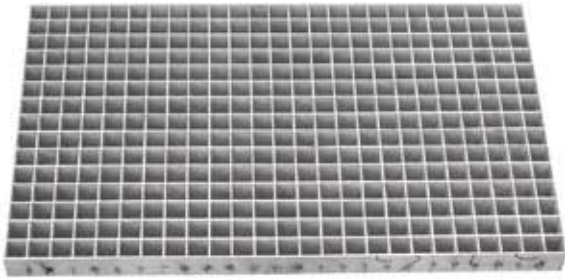

窨井盖系列

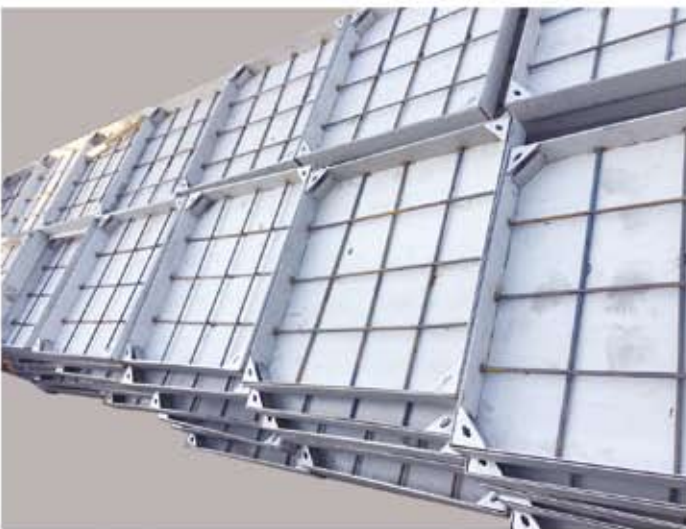

以质量立信誉
Credit establishment by quality

本目录各项产品颜色因印刷及摄影之故，与实物可能有所差异，请先了解。
本目录所有产品，以实物为准，如有更改，恕不另行通知。
本目录版权所有，翻版必究。

All colors of the articles listed in the catalogue may differ from that of the real objects due to photography and printing process.

All articles listed in the catalogue are subject the objets, should any change, correction and alteration on them be occurred, please be noted that it should not be our obligation to inform you of it.

All rights reserved, no copy allowed.

泰州世纪德利金属制品有限公司

地址：江苏省泰州市姜堰区兴泰工业园区

电话：0523-83784304

传真：0523-83786899

手机：18105269678 18936804304

网址：www.cndl.cn

<https://centurydeli.1688.com>

